



PHOENIX

SPECIFICATIONS

MEKKO

BASIN MIXER

PRODUCT CODE: 115-7700-30
 FINISH: GUN METAL
 WELS: 5 STAR - 6.0 LT/MIN

INFORMATION:

TEMPERATURE RATING: MIN 1° - MAX 75°
 PRESSURE RATING: MIN 150 kPa - MAX 500 kPa



AVAILABLE IN:



FOR MORE INFORMATION VISIT
www.phoenixtapware.com.au

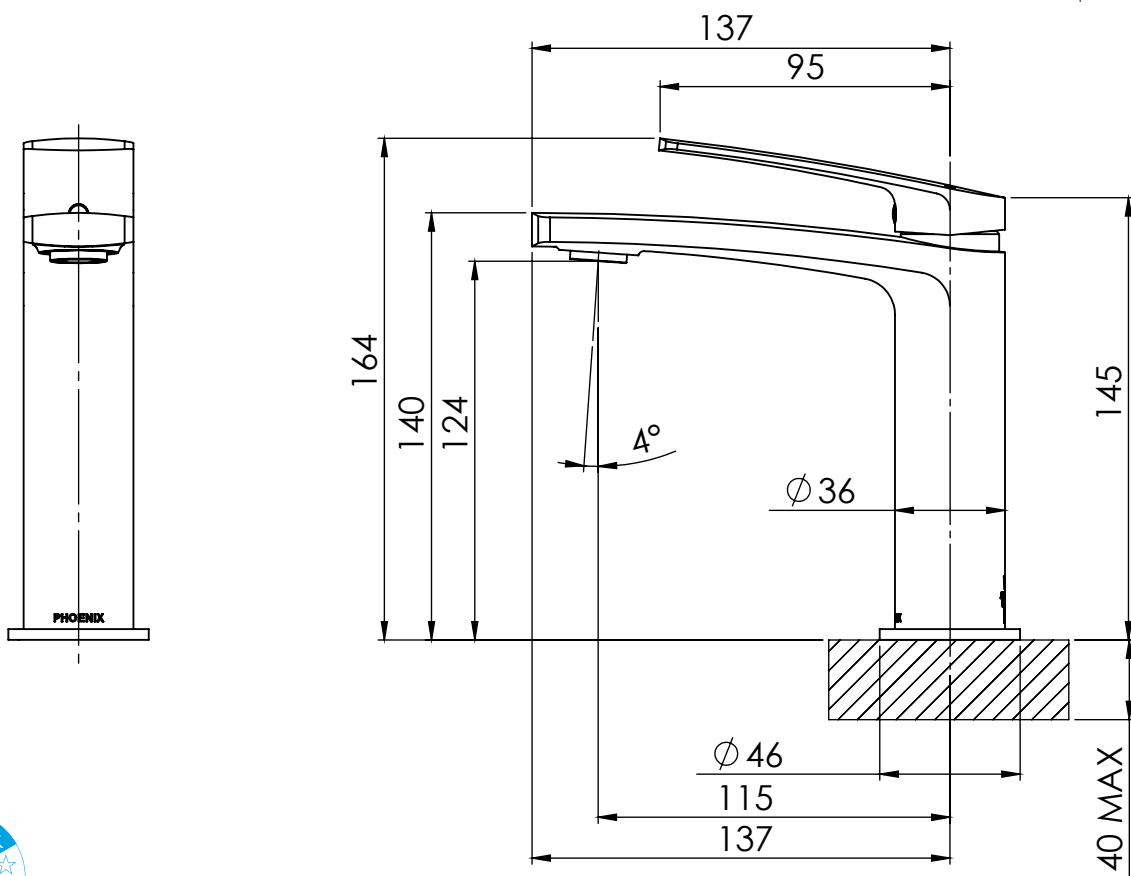

PLEASE [CLICK HERE TO VIEW FULL WARRANTY](#)

While we aim to ensure the specifications shown are correct at time of printing, Phoenix Tapware reserves the right to make modifications without prior notice. Always use the physical product measurements for mark-ups and roughing-in as the line drawing shown may differ from the actual product over time. All measurements are shown in millimetres.

Designed and Registered in Australia by Phoenix Industries Pty. Ltd
 V190618

www.phoenixtapware.com.au
 03 9780 4200



PHOENIX

SPECIFICATIONS

MEKKO

BASIN MIXER

PRODUCT CODE:

115-7700-30

FINISH:

GUN METAL

WELS:

5 STAR - 6.0 LT/MIN



PARTS LIST

1. BASIN BODY
2. CARTRIDGE SEAT
3. O-RING 23X2.5
4. 28MM CARTRIDGE
5. LOCKNUT
6. O-RING 24X1.5
7. DOME
8. HANDLE
9. GRUB SCREW M4X5
10. SCREW CAP
11. AERATOR
12. DRESS PLATE
13. RUBBER WASHER
14. FLEXIBLE HOSE 450MM COLD
15. FLEXIBLE HOSE 450MM HOT
16. GRUB SCREW M5X6
17. M8 THREADED ROD
18. FIXING PLATE
19. RUBBER GASKET

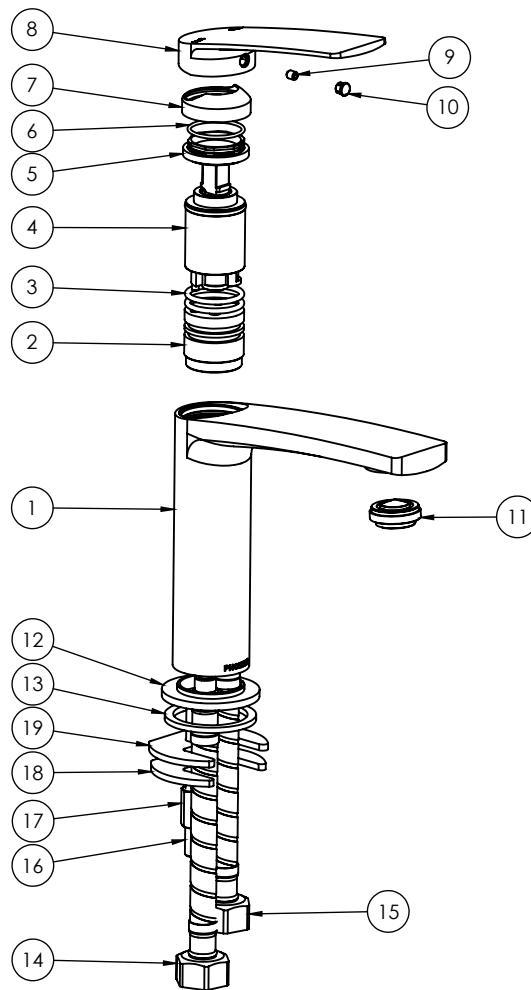

MAINTENANCE AND CARE:

- All surfaces should be cleaned with mild liquid detergent or soap and water.
- Do not use cream cleaners or citrus based cleaning products, as they are abrasive.
- Use of unsuitable cleaning agents may damage the surface. Any damage caused in this way will not be covered by warranty.

PACKAGING INCLUDES

- 1 x Basin mixer
- 1 x 450mm braided flexible cold hose
- 1 x 450mm braided flexible hot hose
- 1 x Installation kit
- 1 x Installation instructions
- 1 x Warranty card

PLEASE [CLICK HERE](#) TO VIEW FULL WARRANTY

While we aim to ensure the specifications shown are correct at time of printing, Phoenix Tapware reserves the right to make modifications without prior notice. Always use the physical product measurements for mark-ups and roughing-in as the line drawing shown may differ from the actual product over time. All measurements are shown in millimetres.

Designed and Registered in Australia by Phoenix Industries Pty. Ltd
VI90618

www.phoenixtapware.com.au
03 9780 4200